



ENJEKSİYON KAMPANA

INJECTION BELLHOUSING



Khazini[®]

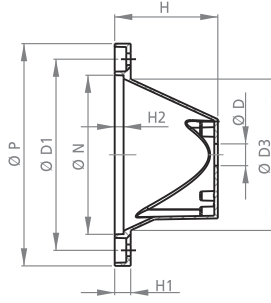
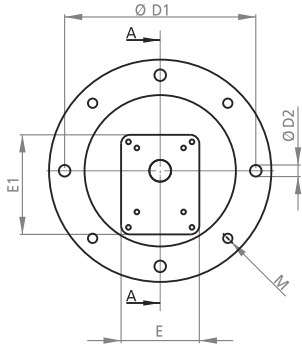

KESİT(SECT.) A-A

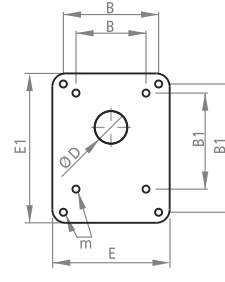

Tip 1 / Type 1

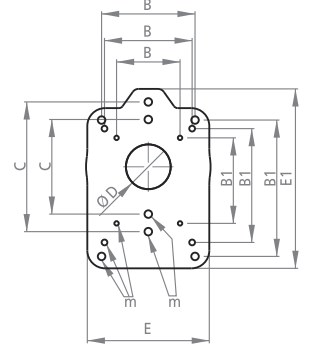

Tip 2 / Type 2

KHAZINI ENJEKSİYON KAMPANA SERİSİ KHAZINI INJECTION BELLHOUSING SERIES

KOD CODE	P	TİP TYPE	H	H1	H2	N	D	D1	D2	D3	B	B1	E	E1	C	m	M
OK 160E80	160	1	80	10	7	110	25.5	130	9	110	52.5	72	88	112	-	6	8
1K 160E80	160	1	80	10	7	110	36.7	130	9	110	71.42	96.18	88	112	-	6	8
OK 200E90	200	1	90	15	7	130	25.5	165	11	135	52.5	72	88	112	-	6	10
1K 200E90	200	1	90	15	7	130	36.7	165	11	135	71.42	96.18	88	112	-	6	10
OK 200E100	200	1	100	15	7	130	25.5	165	11	135	52.5	72	88	112	-	6	10
1K 200E100	200	1	100	15	7	130	36.7	165	11	135	71.42	96.18	88	112	-	6	10
OK 250E115	250	1	115	17	7	180	25.5	215	14	184	52.5	72	88	112	-	6	12
1K 250E115	250	1	115	17	7	180	36.7	215	14	184	71.42	96.18	88	112	-	6	12
1K 3001E134	300	2	134	20	7	230	36.7	265	14	234	71.42	96.18	117	162	-	6	12
2K 3002E134	300	2	134	20	7	230	50.8	265	14	234	98.56	128.02	117	162	-	8	12
KV 3003E134	300	2	134	20	7	230	80.5	265	14	234	-	-	117	162	106.2	10	12
KV 3004E134	300	2	134	20	7	230	82.5	265	14	234	-	-	117	162	106.4	10	12
1K 3501E171	350	2	171	25	7	250	36.7	300	18	260	71.42	96.18	137	200	-	6	16
2K 3502E171	350	2	171	25	7	250	50.8	300	18	260	98.56	128.02	137	200	-	8	16
3K 3503E171	350	2	171	25	7	250	60.5	300	18	260	105.1	153.37	137	200	-	8	16
KV 3504E171	350	2	171	25	7	250	80.5	300	18	260	-	-	137	200	106.2	10	16
KV 3505E171	350	2	171	25	7	250	82.5	300	18	260	-	-	137	200	106.4	10	16
KV 3506E171	350	2	171	25	7	250	101.8	300	18	260	-	-	137	200	145.9	10	16
KV 3501E191	350	2	191	25	7	250	80.5	300	18	260	-	-	137	220	106.2	10	16
KV 3502E191	350	2	191	25	7	250	82.5	300	18	260	-	-	137	220	106.4	10	16
KV 3503E191	350	2	191	25	7	250	101.8	300	18	260	-	-	137	220	145.9	12	16
KV 3504E191	350	2	191	25	7	250	127	300	18	260	-	-	137	220	180.85	16	16
KR 3501E191	350	2	191	25	7	250	80/100	300	18	260	-	-	137	137	-	-	16

Motor Flaş Çapları için sayfa 26'ya bakınız.

Look at the page 26 for Flange Diameters of Engine.

Patent No : 2011 / 87879